

FS-5920-W 13#/Cpc
WIREWAY END CAP FOR FS-200 CHANNEL

For FS-200 Channel

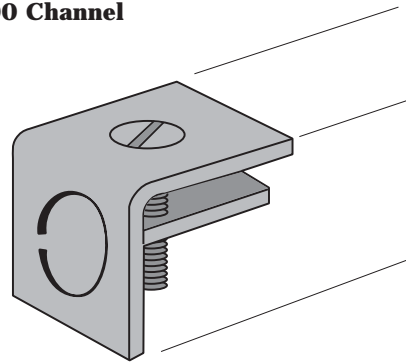

FS-5940-1/2" END CAP WITH 1/2" KNOCKOUT
26# / Cpc

FS-5940-3/4" END CAP WITH 3/4" KNOCKOUT
26# / Cpc

FS-5940 Series

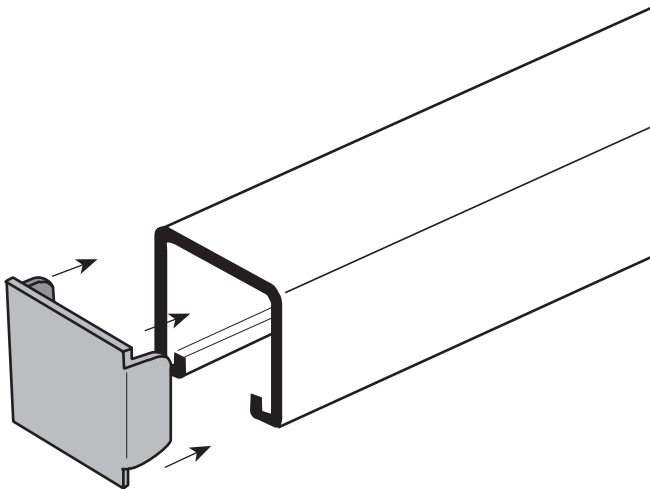

FS-5910 SINGLE PIECE END CAP FOR FS-100 CHANNEL
15# / Cpc

FS-5915 SINGLE PIECE END CAP FOR FS-150 CHANNEL
6# / Cpc

FS-5920 SINGLE PIECE END CAP FOR FS-200 CHANNEL
5# / Cpc

FS-5921 SINGLE PIECE END CAP FOR FS-210 CHANNEL
5# / Cpc

FS-5933 SINGLE PIECE END CAP FOR FS-300 CHANNEL
4# / Cpc

FS-5934 SINGLE PIECE END CAP FOR FS-400 CHANNEL
4# / Cpc

FS-5935 SINGLE PIECE END CAP FOR FS-500 AND FS-450 CHANNEL
4# / Cpc

FS-5910 thru FS-5935

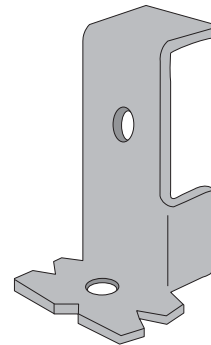

FS-5952 ANCHOR END CAP FOR FS-200 CHANNEL
21# / Cpc

FS-5953 ANCHOR END CAP FOR FS-300 CHANNEL
21# / Cpc

FS-5954 ANCHOR END CAP FOR FS-400 CHANNEL
21# / Cpc

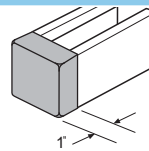

PLASTIC END CAPS FOR SECTIONS

Part No.	Color	Channel Size	#/Cpc
FS-5960-1W	White	FS-100	5
FS-5960-15B	Black	FS-150	5
FS-5960-2BL	Blue	FS-200	4
FS-5960-2R	Red	FS-200	4
FS-5960-2W	White	FS-200	4
FS-5960-2Y	Yellow	FS-200	4
FS-5960-2BR	Brown	FS-200	4
FS-5960-2B	Black	FS-200	4
FS-5960-5R	Red	FS-500	4
FS-5960-5W	White	FS-500	4
FS-5960-7B	Black	FS-700	2

Also Available in Other Standard Strut Sizes

HANGERS & ELECTRICAL ACCESSORIES

25#/Cpc

Design Load = 250#

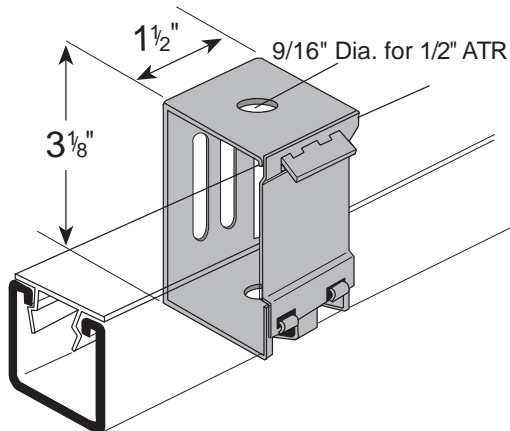

FS-6420
CHANNEL HANGER

4#/Cpc

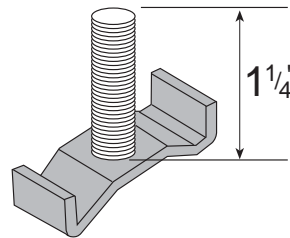

FS-6460
FIXTURE STUD NUT

2#/Cpc

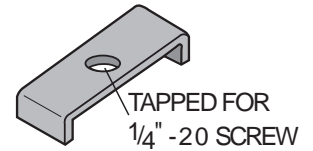

FS-6461
FIXTURE NUT

27#/Cpc

Design Load = 150#

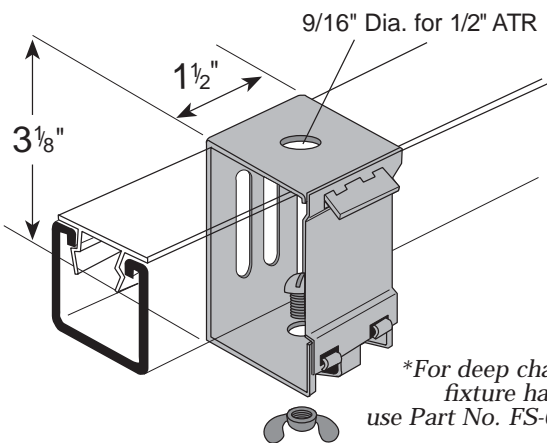

FS-6422
FIXTURE HANGERS

**For deep channel fixture hanger, use Part No. FS-6426*

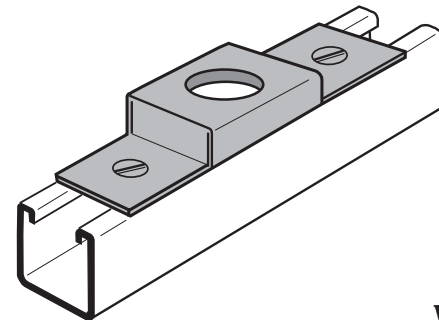

Cat. No.	Use With	Hole	Weight Lbs./C
FS-6442	1/2" Conduit	7/8"	28
FS-6443	3/4" Conduit	1-3/32"	28

Assembly includes Strut Nuts and Flat Head Machine Screws

FS-6442
CONDUIT CONNECTOR

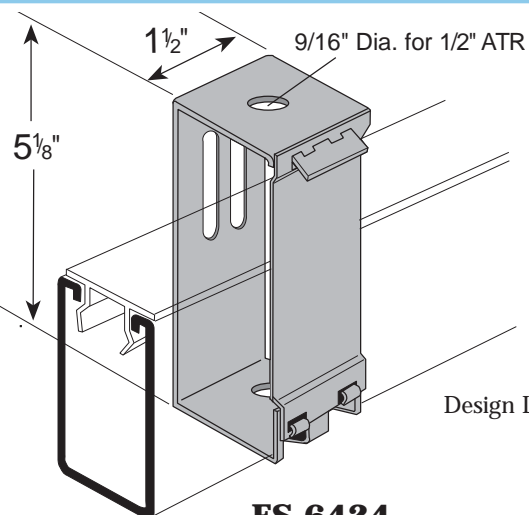

FS-6424
DEEP CHANNEL HANGER

45#/Cpc

Design Load = 250#

8#/Cpc

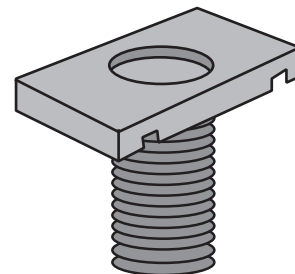

FS-6462
WIRING STUD NUT

HANGERS & ELECTRICAL ACCESSORIES

Includes (4) 1/4" -20
Hex Nuts

134#/Cpc

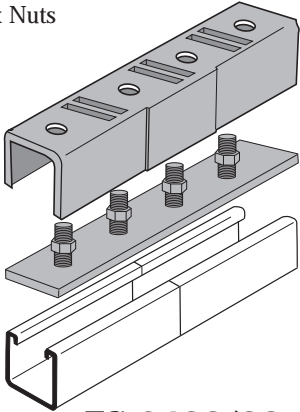

FS-6432/39

INCLUDES

- FS-6432-SPLICE CLEVIS
- FS-6439 STUD PLATE

Includes (4) 1/4" -20
Flathead Screws

132#/Cpc

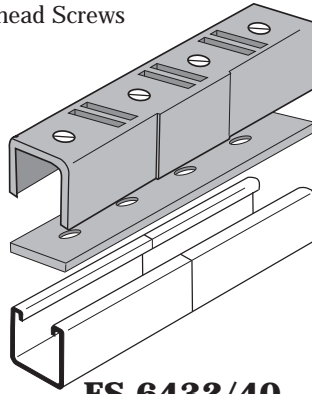

FS-6432/40

INCLUDES

- FS-6432-SPLICE CLEVIS
- 1/4" -20FHMS
- FS-6440 TAPPED PLATE

For FS-200 Channel

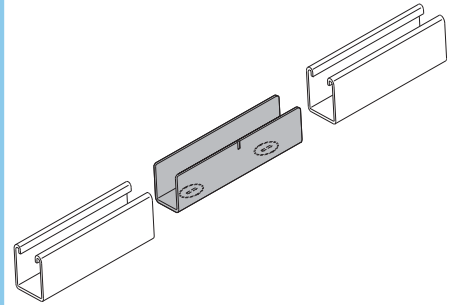

FS-6441

IN-LINE STRUT JOINER

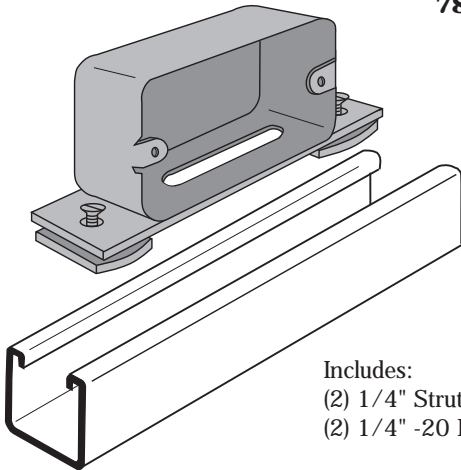

78#/Cpc

Includes:
(2) 1/4" Strut Nuts
(2) 1/4" -20 FHMS

**FS-6445
OUTLET BOX**

SWIVEL HANGERS

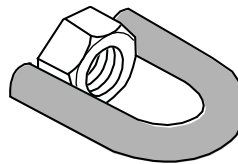

**FS-6471-3/8
FS-6471-1/2**

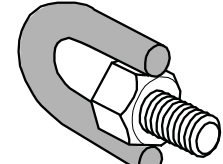

**FS-6481-3/8
FS-6481-1/2**

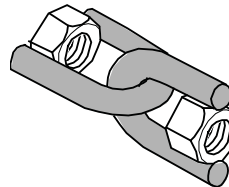

**FS-6472-3/8
FS-6472-1/2**

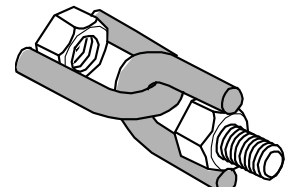

**FS-6482-3/8
FS-6482-1/2**

19 Ga. (.040) Steel and Aluminum
Finish: Plain / Green / Galvanized / Aluminum

47#/Cft

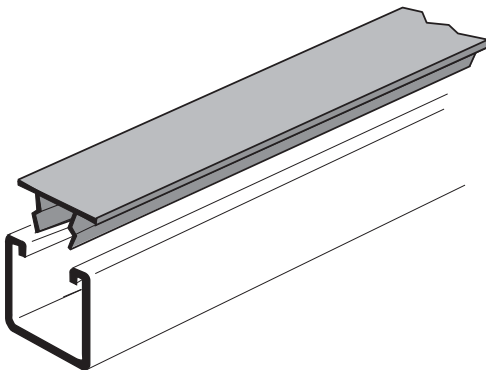

**FS-6500
CLOSURE STRIP (ELECTRICAL COVER)
STEEL OR ALUMINUM**

Plastic Available In:
Black / White / Green / Gray

8#/Cft

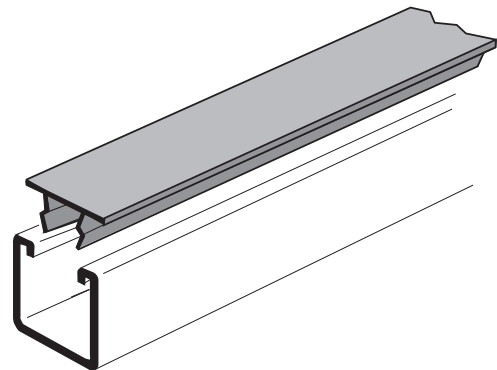

**FS-6518
CLOSURE STRIP
PLASTIC**